



# Enhanced Thermal Performance of Shell and Tube Heat Exchangers Using TiO<sub>2</sub>/Water Nanofluids: An SST Turbulence Model Analysis



Wilson Babu Musinguzi<sup>1\*</sup>, Pengfei Yu<sup>2</sup>

<sup>1</sup> Faculty of Science, Technology and Innovation, Mountains of the Moon University, 837 Fort Portal, Uganda

<sup>2</sup> Nanjing Institute of Technology, School of Energy and Power Engineering, 211167 Nanjing, China

\* Correspondence: Wilson Babu Musinguzi ([wilson.musinguzi@mmu.ac.ug](mailto:wilson.musinguzi@mmu.ac.ug))

**Received:** 08-14-2023

**Revised:** 09-18-2023

**Accepted:** 09-24-2023

**Citation:** W. B. Musinguzi and P. F. Yu, “Enhanced thermal performance of shell and tube heat exchangers using TiO<sub>2</sub>/water nanofluids: An SST turbulence model analysis,” *J. Sustain. Energy*, vol. 2, no. 3, pp. 154–164, 2023. <https://doi.org/10.56578/jse020305>.



© 2023 by the author(s). Published by Acadlore Publishing Services Limited, Hong Kong. This article is available for free download and can be reused and cited, provided that the original published version is credited, under the CC BY 4.0 license.

**Abstract:** Over recent years, nanotechnology’s landscape has witnessed transformative advancements, heralding new research opportunities in scientific and engineering domains. A notable innovation in this evolution is the development of nanofluids, comprising nanoparticles (each under 100 nm in diameter) suspended in conventional heat transfer fluids such as ethylene glycol and water. Distinguished from traditional heat transfer fluids, nanofluids are posited to offer substantial enhancements, particularly in thermal characteristics. The dispersion of nanoparticles, even in minimal quantities, within base fluids markedly improves the thermal properties of these fluids. This study focuses on evaluating the thermal performance of a shell and tube heat exchanger utilizing the shear stress transport (SST) turbulence model. ANSYS CFX, acclaimed for its accuracy, robustness, and expedience in various turbulence models, is employed for this analysis. The SST model is particularly effective in non-equilibrium turbulent boundary layer flows, enabling accurate heat transfer predictions. ANSYS CFX’s approach to near-wall equations mitigates the stringent grid resolution requirements often encountered in computational fluid dynamics (CFD) applications. The investigation encompasses the use of water and TiO<sub>2</sub>/water nanofluid at varying concentrations (1%, 2%, 3%, 4%, 5%) in a 3D model and CFD simulation. Enhanced efficiency and cooling performance are observed with the introduction of nanofluids in the shell and tube heat exchanger.

**Keywords:** Nanofluids; Nanoparticles; Heat transfer fluids; Thermal characteristics; Shear stress transport turbulence model; ANSYS CFX software; Computational fluid dynamics; Water; TiO<sub>2</sub>/water nanofluid; Concentrations

## 1 Introduction

The unprecedented growth of the global population and the continued reliance on fossil fuels have significantly exacerbated concerns regarding the ozone layer’s depletion and the escalating phenomenon of global warming. This situation necessitates the development of thermal systems surpassing the efficiency of existing technologies. In response, this research delves into the field of nanotechnology, with a particular focus on a class of fluids known as nanofluids. These fluids, emerging from advancements in nanotechnology, offer a revolutionary approach to enhancing the thermal properties of conventional fluids. The introduction of nanoparticles, each with a diameter ranging from 1 to 100 nm, into standard fluids results in a marked increase in thermal conductivity compared to the base fluids. Nanofluids demonstrate superior heat exchange capabilities, a testament to their transformative properties.

This study aims to evaluate the thermal characteristics of shell and tube heat exchangers using the SST turbulence model. Employing the ANSYS CFX software, known for its precision and versatility across various turbulence models, the research investigates the complex dynamics within these systems. The integration of TiO<sub>2</sub>/water nanofluid at varying concentrations is explored to achieve unprecedented efficiency and performance enhancements. The intersection of nanotechnology and thermal analysis offers promising avenues for addressing environmental challenges and enhancing technological efficiency. The goal of this study is to contribute meaningful insights that foster the development of sustainable and efficient thermal systems, marking a new chapter in environmental stewardship and technological progress.

Significant progress in the study of nanofluids has been made over the years. For instance, in a pioneering theoretical study by Yang et al. [1], a significant correlation was discovered between the Nusselt number of titanium water nanofluids and the bulk mean nanoparticle volume fraction. This discovery highlights the intricate relationship between nanoparticle concentration and heat transfer properties, underscoring the complexities inherent in nanofluid research. The research conducted by Sekhar et al. [2] identified a significant correlation between particle concentration, the Nusselt number, and the friction factor in nanofluid dynamics. The study's findings, revealing a decrease in friction factors with an increase in the Reynolds number and an upward trend in the Nusselt number, open new avenues for exploring the dynamic behavior of nanofluids. Moreover, the research highlighted the transformative impact of nanofluids, particularly those with high heat exchange coefficients, on enhancing system efficiency.

In another pivotal study, Hussein et al. [3] examined the viscosity and thermal conductivity of nanofluids, providing a nuanced understanding of these fluids' enhanced properties. The observed increase in viscosity and thermal conductivity with rising nanofluid concentration not only illuminates the physical characteristics of these fluids but also paves the way for their application in system design and optimization. The comparative analysis between circular and flat tubes in this study adds a layer of complexity, underscoring the need for custom solutions tailored to the specific geometry of heat exchangers. Ali and Yunus [4] contributed valuable insights into how particle size affects the thermal properties of  $\text{Al}_2\text{O}_3$  nanofluids. The study's consideration of factors such as the interfacial layer between solids and liquids, the ballistic energy involved, and the mechanisms of heat transfer within nanoparticles lays the groundwork for a comprehensive understanding of nanofluid behavior. The trend of increasing thermal conductivity and diffusivity with higher volume fraction concentrations further illustrates the complex relationship between nanofluid composition and heat transfer characteristics.

Heris et al. [5] demonstrated a notable increase in the heat transfer coefficient using nanofluids with higher nanoparticle concentrations, especially at increased flow rates. The reduction in wall temperature, as evidenced by the use of nanofluids, adds a practical aspect to the theoretical findings, showcasing the potential for real-world applications of nanofluid-enhanced heat transfer. Liu et al. [6] provided an extensive elucidation of the thermodynamic vent system (TVS), focusing on the crucial role of optimizing cold storage capacity to enhance the efficiency of heat exchangers. The findings, corroborated by pertinent experimental data, establish a concrete connection between theoretical principles and practical applications within thermal systems. In the realm of heat exchanger research, Ozden and Tari [7] conducted an in-depth investigation into the heat transfer characteristics of a helical coiled twin-pipe heat exchanger. By comparing counter-flow and parallel flow configurations and employing CFD for validation against empirical data, the study not only fortified its findings but also underscored the significance of advanced modeling techniques in heat exchanger dynamics analysis. The observed similarities in heat transmission capacities between counter-flow and parallel-flow configurations invite further exploration into the optimal design for specific application scenarios.

Shedid [8] undertook a numerical analysis to explore the relationship between the concentration ratio of  $\text{Al}_2\text{O}_3$  and  $\text{TiO}_2$  nanoparticles and the Nusselt number. The simulations provided quantitative insights into how nanoparticle concentration influences heat transfer characteristics, thereby laying the groundwork for future enhancements in nanofluid applications. A noteworthy study by Asadbeigi et al. [9] focused on the pasteurization process using a shell and tube heat exchanger. Utilizing ANSYS Fluent software for a 3D CFD model, the research examined the effect of pasteurization on the viscosity of tomato purée, employing the Herschel Bulkley model. The CFD simulations, closely aligning with experimental data, projected an output temperature of  $79^\circ\text{C}$  for the tomato paste. This comprehensive evaluation of the heat exchanger's performance across various hot water mass flow rates emphasizes the potential of CFD in refining heat exchanger design for improved energy efficiency, particularly in the food processing industry.

Wu et al. [10] conducted an innovative study on the integration of phase transition materials and nanoparticles in shell and tube heat exchangers for the purpose of solar energy harvesting. This research thoroughly examined various combinations of nanoparticle types, focusing on their impact on thermal storage capabilities. It was discovered that hybrid Nano-phase change material (PCM) shell and tube heat exchangers, particularly those incorporating ternary Nano-PCM, demonstrated enhanced performance in energy storage rate and capacity. These findings offer significant insights into the optimization of hybrid nanoparticle designs for more effective solar thermal utilization, marking a step forward in renewable energy technology development. Abidi and Sajadi [11] dedicated their research to improving the thermo-hydraulic efficiency of shell-and-tube heat exchangers through computational analysis. The study utilized a hybrid nanofluid composed of  $\text{Fe}_3\text{O}_4$ -Multi-Walled Carbon Nanotube (MWCNT) and water. The results indicated a positive correlation between the baffle angle and the average Nusselt number, highlighting the efficacy of baffles and nanofluids in such systems. This work contributes to a deeper understanding of the hydraulic characteristics and thermal efficiency of shell-and-tube heat exchangers, providing valuable insights into the factors that influence their performance under varying conditions.

Han et al. [12] tackled the complexities involved in heat exchanger design by employing the Kern and Bell-

Delaware methodologies to develop a thermal-economic model. The study introduced an advanced sparrow search algorithm for optimization purposes, yielding significant reductions in annual expenditure and spatial requirements when compared to traditional methods. This research underscores the potential of sophisticated optimization techniques in realizing economic benefits, demonstrating both cost reductions and enhanced efficiency in heat exchanger design. This extensive review of the literature not only highlights the diverse aspects of nanofluid research but also elucidates the complex relationship between nanoparticle concentration, fluid dynamics, and heat transfer characteristics. The incorporation of CFD simulations, empirical validations, and theoretical frameworks has significantly enriched the understanding of nanofluids and their potential in enhancing heat exchanger efficiency. This thorough exploration not only deepens the knowledge of nanofluids but also lays a solid groundwork for future advancements in heat transfer technology, providing a strong foundation for the subsequent chapters of this study.

In the existing realm of heat exchanger research, a notable gap is evident, stemming from the widespread reliance on conventional fluids and the k-epsilon turbulence model. This prevalent approach frequently results in the underestimation of flow separation characteristics, leading to potential inaccuracies in assessing the heat transfer coefficient (HTC). Such discrepancies impede the precision of heat exchanger design and limit the optimization of thermal systems for improved efficiency. This identified gap necessitates the exploration of the more accurate SST turbulence model, which offers a more precise depiction of flow separation dynamics. Addressing this deficiency in existing methodologies, the present study aims to establish a robust foundation for future research in heat exchangers. It ensures that the evaluation of thermal characteristics is based on accurate and reliable turbulence modeling, thus enhancing the precision and efficacy of heat exchanger designs. Contemporary studies in heat exchanger research predominantly focus on conventional fluids, characterized by moderate thermophysical properties, thereby overlooking the potential for significantly enhanced efficiency. This narrow exploration of unconventional fluids and advanced turbulence models underlines an urgent need to expand the scope of research in this domain. The imperative for such expansion is driven not only by academic interests but also by the practical necessity of improving heat transfer technologies, vital for addressing energy efficiency and environmental sustainability.

Consequently, the emergent research question transcends academic inquiry, becoming a practical necessity: How can the application of the SST turbulence model and the exploration of TiO<sub>2</sub>/water nanofluids at varying concentrations address these limitations and augment heat exchanger efficiency? In response, this research hypothesizes that the use of the SST turbulence model will result in a more precise assessment of thermal characteristics, and that TiO<sub>2</sub>/water nanofluids will demonstrate superior performance compared to conventional fluids. By articulating these hypotheses, the study aims not only to contribute to theoretical knowledge but also to address the practical implications of these advancements in actual thermal systems. Thus, the overarching problem statement underscores the need to bridge these identified gaps. The research is designed to apply the SST turbulence model for a meticulous evaluation of thermal characteristics in a shell and tube heat exchanger. Additionally, the study explores the untapped potential of TiO<sub>2</sub>/water nanofluids, aiming to advance thermal system technologies. The ultimate goal is to fill existing knowledge gaps and unveil new opportunities for improved heat transfer technologies, fostering innovation in the broader field of thermal engineering and contributing to the sustainable development of energy-efficient systems.

## 2 Methodology

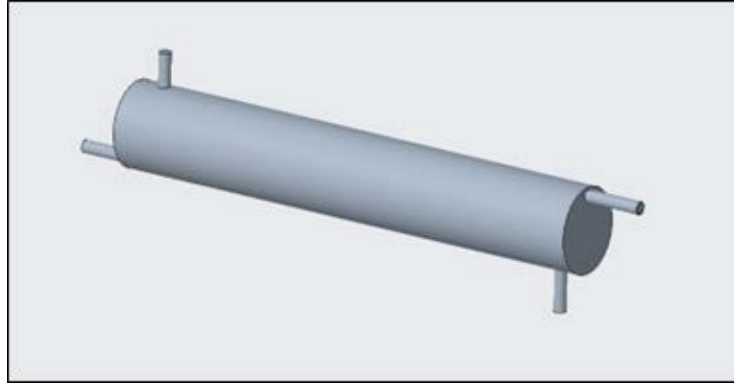
The CFD technique is employed as the foundational methodology for this comprehensive investigation. The analysis is structured into three phases: pre-processing, solution, and post-processing, each critical to the integrity of the research findings [13].

### 2.1 Pre-Processing Stage

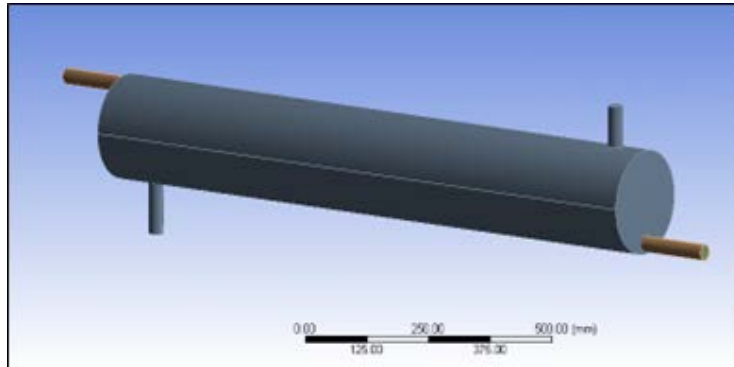
This initial stage encompasses several vital steps. The shell and serpentine heat exchanger is first modeled using Creo Parametric software. This process involves assembly and component modeling techniques to accurately represent the heat exchanger in a digital format. The model's key geometric dimensions include a heat exchanger length of 1300mm, a shell outer diameter of 200mm, a shell thickness of 3.2mm, a tube outer diameter of 30mm, and a tube thickness of 1.5mm, as depicted in Figure 1.

The CAD model, as shown in Figure 2 and meticulously crafted in Creo, is then imported into ANSYS Workbench, initiating the integration of CAD design and numerical simulation [14]. The model undergoes comprehensive examination and refinement within ANSYS DesignModeler software to rectify any potential geometric inaccuracies.

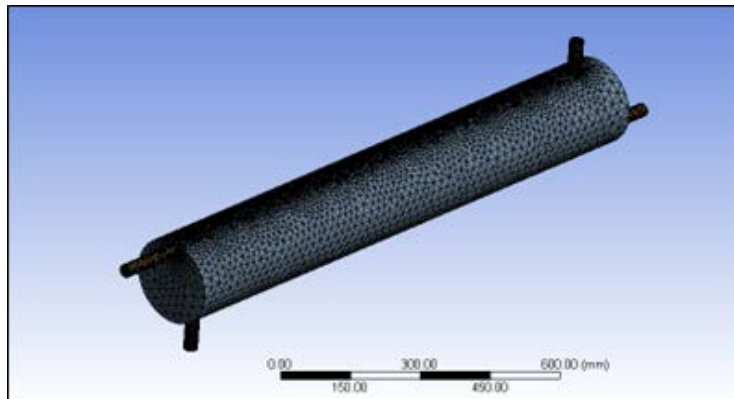
Mesh generation, a pivotal step in the CFD process, is executed using tetrahedral elements, conforming to predetermined specifications and mesh density as illustrated in Figure 3. Critical parameters, such as the relevance parameter (set at 100), mesh size (fine), and inflation parameter (default value), are precisely configured to optimize the accuracy of the simulations that follow.



**Figure 1.** Computer aided design (CAD) model of shell and serpentine heat exchanger



**Figure 2.** CAD model of heat exchanger



**Figure 3.** Meshed model of heat exchanger

## 2.2 Solution Stage

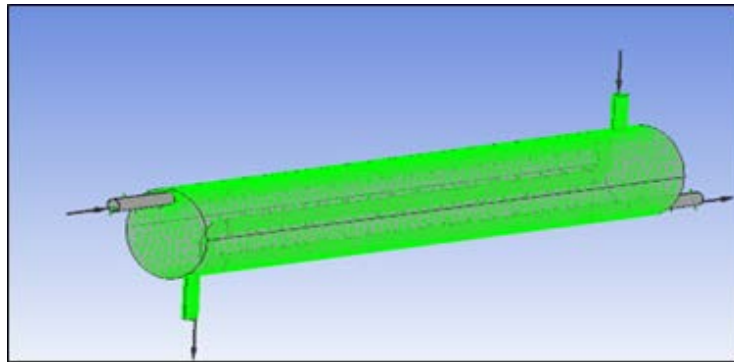
In the solution phase, the solver program conducts matrix formulations, multiplications, and inversions. Central to the CFD methodology is the Navier-Stokes equation, which is based on the principles of mass, momentum, and energy conservation [15]. These governing equations are fundamental to the numerical computations that elucidate the complex fluid dynamics within the heat exchanger.

## 2.3 Post-Processing Stage

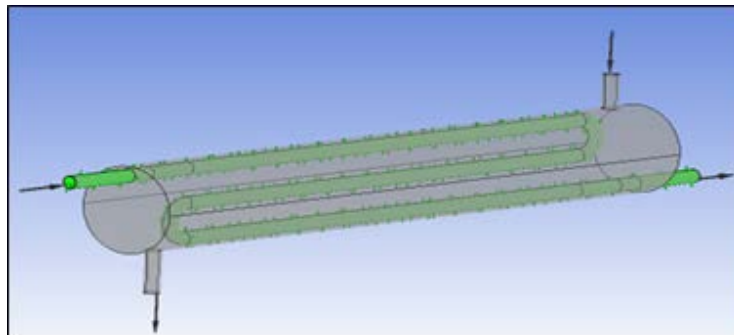
The post-processing phase involves the analysis and interpretation of the simulation results. Pressure and temperature plots are examined in detail, yielding insights into the system's thermal characteristics. Additionally, optimization processes, whether targeting design parameters or material considerations, are undertaken to enhance system performance.

The computational domain for the shell and tube heat exchanger is rigorously defined, with the fluid domain segregated into shell and tube regions. These regions are assigned distinct fluid types, water in the shell and nanofluid

in the tubes, as illustrated in Figure 4 and Figure 5. The nanofluid's definition encompasses essential thermophysical properties such as thermal conductivity, density, and kinematic viscosity.

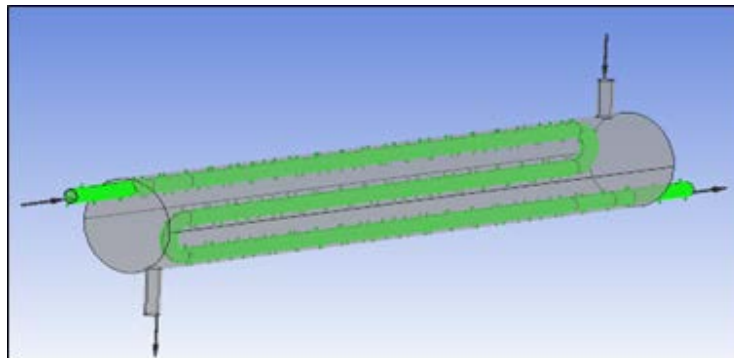


**Figure 4.** Shell domain definition



**Figure 5.** Tube fluid definition

Material properties are crucial for accurately representing the physical system. As shown in Figure 6, the tube is classified as a solid domain, with its material properties designated as aluminum. The heat transfer mechanism within the tube is explicitly defined as thermal energy transfer.



**Figure 6.** Tube material definition

## 2.4 Selection of SST Turbulence Model and Solver Settings

For the simulation of real-world conditions, the computational setup includes the definition of the cold fluid inlet, characterized by a mass flow rate of 0.05 Kg/s and a static temperature of 300K. The SST turbulence model is chosen for its ability to blend a variant of the  $k - \omega$  model in the inner boundary layer with a transformed version of the  $k - \omega$  model in the outer boundary layer and away from the wall [16]. The SST model is particularly advantageous for non-equilibrium turbulent boundary layer flows, critical for accurate heat transfer predictions. This model is also noted for its innovative approach to handling near-wall equations in ANSYS CFX, which reduces the need for stringent grid resolution requirements typical of other CFD software. Solver settings are meticulously calibrated for

the shell and tube heat exchanger's computational domain. Root Mean Square (RMS) residual settings are established at 0.0001 to ensure convergence, and a high-resolution advection scheme is implemented to capture detailed flow patterns.

The rationale for selecting the SST turbulence model lies in its robustness in predicting non-equilibrium turbulent boundary layer flows, a vital aspect for accurate heat transfer analysis in this study. The unique handling of near-wall equations by the CFX solver not only enhances efficiency but also obviates the need for excessive grid resolutions, facilitating a more streamlined simulation process.

In summary, the methodology detailed herein adheres to established best practices in CFD simulation, with a particular focus on the application of the SST turbulence model and the precise definition of material properties. The integration of rigorous CAD modeling into the ANSYS Workbench platform exemplifies the methodological precision employed in this study.

### 3 Results

The CFD simulations have yielded detailed insights into the thermal and fluid flow dynamics within the shell and tube heat exchanger. The findings, both qualitative and quantitative, elucidate the complex interaction between temperature and velocity distributions, especially with the introduction of nanofluids into the system.

#### 3.1 Temperature Distribution with Water

Figure 7 depicts the temperature distribution across the mid-plane of the shell and serpentine heat exchanger when water is used as the working fluid.

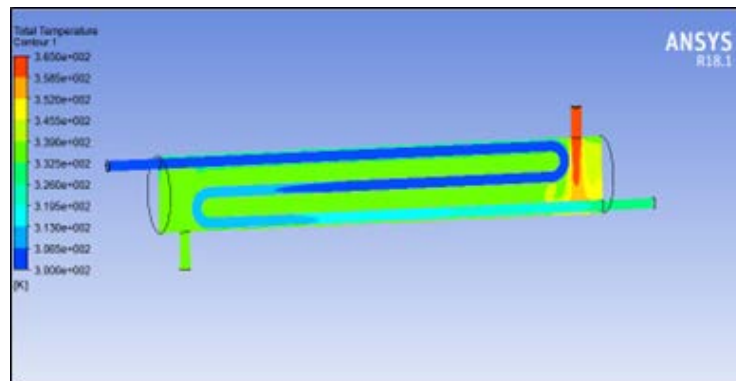


Figure 7. Temperature distribution with water as fluid

The inlet temperature is observed at 359K, gradually decreasing to 338K along the shell's length. These results are consistent with the findings in existing literature [7], affirming the numerical simulations' accuracy.

#### 3.2 Velocity Distribution with Water

As shown in Figure 8, the velocity distribution when water is employed as the fluid indicates a higher velocity magnitude at the tube's curvature, both at the top and bottom, reaching approximately 0.117m/s.

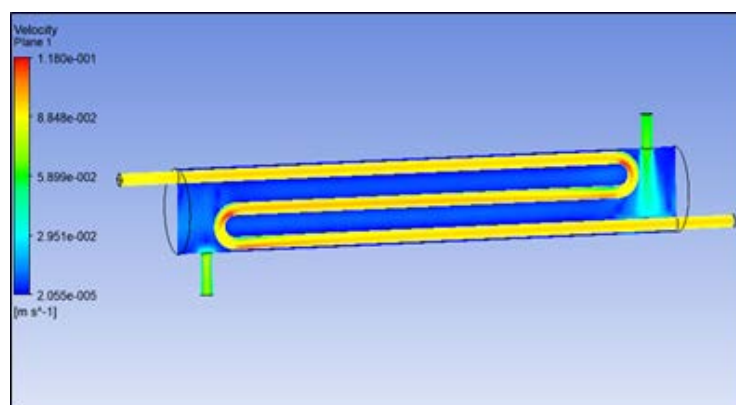


Figure 8. Velocity distribution with water as fluid

In other regions of the tube, a slightly lower velocity of 0.088m/s is noted. This elevated velocity at the tube's curvature is indicative of enhanced fluid mixing and improved heat transfer efficiency.

### 3.3 Nanofluid Analysis

The investigation extends to examining the thermal and flow characteristics of nanofluids at various concentrations (1%, 2%, 3%, 4%, and 5%).

#### 1% nanofluid concentration:

For the 1% nanofluid concentration, Figure 9 demonstrates an inlet temperature of 362K, which decreases progressively to 325K along the shell's length. Correspondingly, Figure 10 reveals a consistently higher velocity throughout the tube, peaking at approximately 0.116m/s, which illustrates the impact of nanofluid concentration on fluid dynamics.

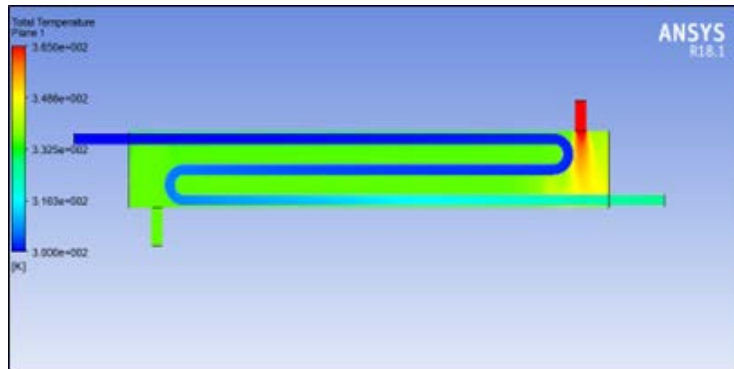


Figure 9. Temperature distribution with 1% nanofluid

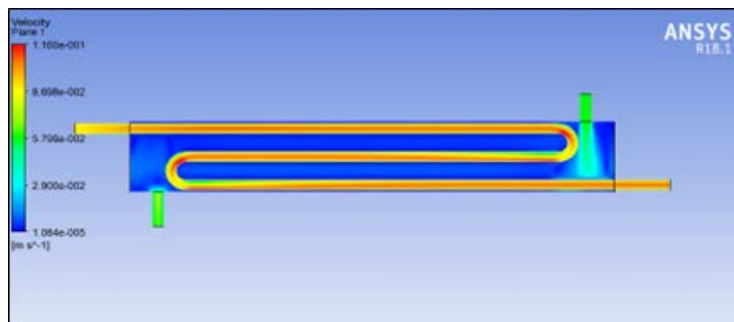


Figure 10. Velocity distribution with 1% nanofluid

#### 2% nanofluid concentration:

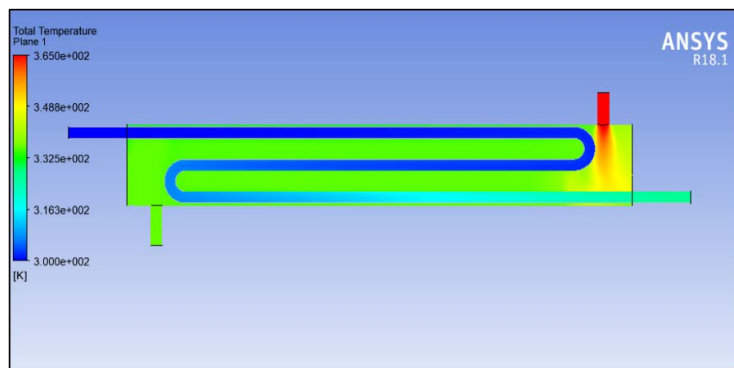
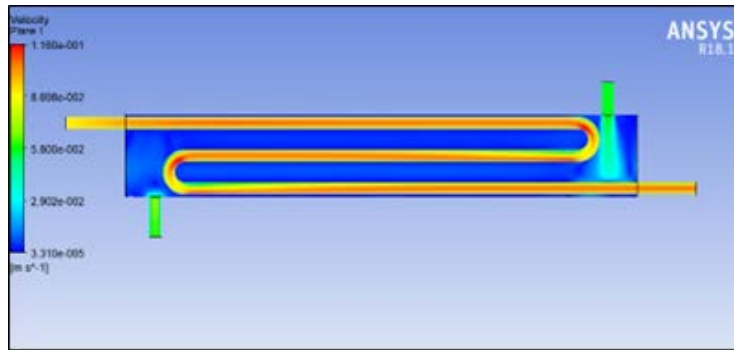


Figure 11. Temperature distribution with 2% nanofluid

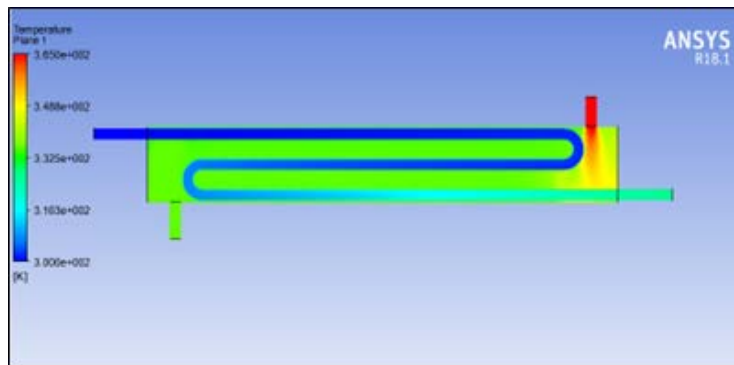
In the case of 2% nanofluid concentration, as depicted in Figure 11, the inlet temperature is observed at 364.2K, reducing to 322K along the shell. Concurrently, Figure 12 shows a velocity magnitude throughout the tube, reaching approximately 0.1142m/s, reinforcing the correlation between nanofluid concentration and velocity dynamics.



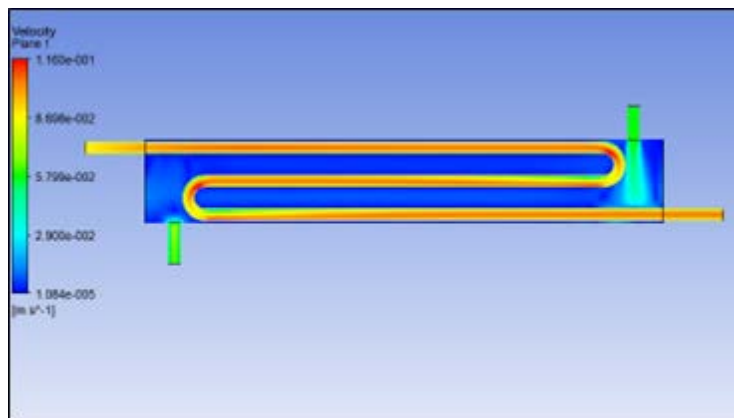
**Figure 12.** Velocity distribution with 2% nanofluid

**3% nanofluid concentration:**

With 3% nanofluid concentration (Figure 13), the inlet temperature is noted at 364.1K, decreasing to 321.8K along the shell. The velocity profile, as shown in Figure 14, exhibits increased magnitudes throughout the tube, with a maximum of approximately 0.1148m/s. These observations underscore the consistent influence of nanofluid concentration on the temperature and velocity profiles within the heat exchanger.



**Figure 13.** Temperature distribution with 3% nanofluid



**Figure 14.** Velocity distribution with 3% nanofluid

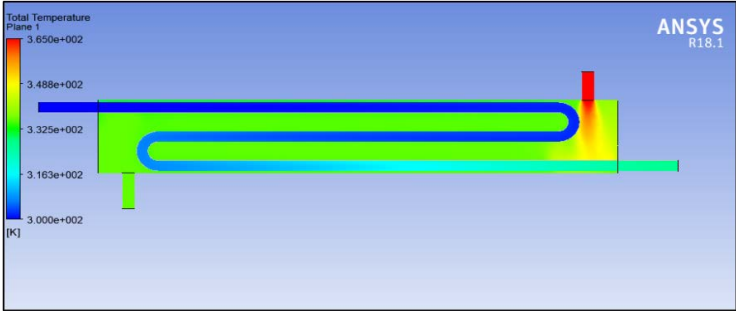
**4% and 5% nanofluid concentrations:**

The temperature profiles for 4% nanofluid concentration, as shown in Figure 15, and for 5% nanofluid concentration, depicted in Figure 16, are observed with inlet temperatures of 363.28K and 363.17K, respectively. These profiles demonstrate the nuanced influence of increased nanofluid concentrations on thermal dynamics within the shell.

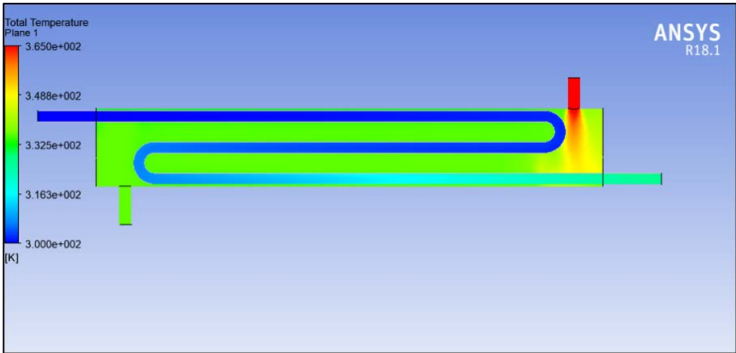
Concurrently, Figure 17 and Figure 18 depict the velocity distributions for 4% and 5% nanofluid concentrations, respectively. These figures illustrate elevated velocity magnitudes throughout the tube, highlighting the significant impact of nanofluid concentration on fluid flow dynamics. Notably, the enhanced velocity observed at the curvature



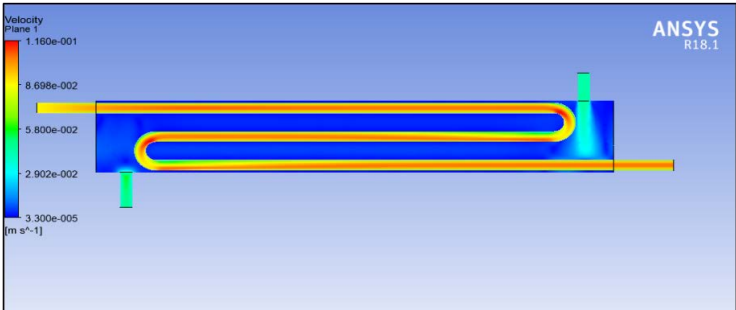
of the tube indicates improved fluid mixing and increased heat transfer efficiency. This observation is pivotal, as it has substantial implications for the overall performance and efficiency of the heat exchanger.



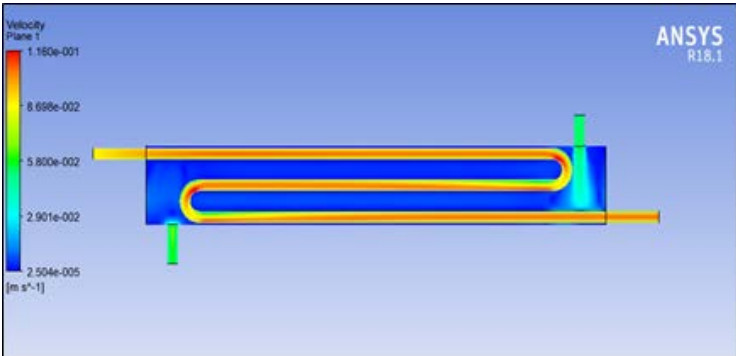
**Figure 15.** Temperature distribution with 4% nanofluid



**Figure 16.** Temperature distribution with 5% nanofluid



**Figure 17.** Velocity distribution with 4% nanofluid



**Figure 18.** Velocity distribution with 5% nanofluid

### 3.4 Comparative Analysis of Effectiveness

Table 1 elucidates the comparative effectiveness of TiO<sub>2</sub>/water nanofluids against water in the shell and tube heat exchanger. The tabulated effectiveness values distinctly show an improvement in the performance with nanofluids, underscoring their capability to augment heat transfer efficiency.

**Table 1.** Effectiveness of TiO<sub>2</sub>/water nanofluid

Fluid	Effectiveness
Water	0.519
1% nanofluid	0.536
2% nanofluid	0.539
3% nanofluid	0.536
4% nanofluid	0.542
5% nanofluid	0.548

The trends observed in temperature and velocity distributions confirm the beneficial impact of nanofluids on the thermal and fluid flow dynamics within the heat exchanger. Notably, the increased velocity magnitudes, particularly at the curvature of the tube, suggest more efficient fluid mixing and enhanced heat transfer. These findings are in accordance with prior studies [7], lending credibility to the accuracy of the current numerical simulations.

The steady enhancement in effectiveness across various nanofluid concentrations further highlights the potential of specifically TiO<sub>2</sub>/water nanofluids in elevating the overall performance of shell and tube heat exchangers. The detailed examination of temperature and velocity profiles provides essential insights for optimizing heat exchanger design and operation, thereby advancing the development of more efficient and sustainable thermal systems. These observed trends lay a foundation for future research initiatives, driving forward the exploration of nanofluids in improving heat transfer efficiency.

## 4 Conclusions

This study has made significant contributions to the understanding of heat transfer in shell and tube heat exchangers, with a particular focus on the potential of TiO<sub>2</sub>/water nanofluids. Employing the SST turbulence model, an in-depth exploration of thermal characteristics and fluid dynamics in the context of various nanofluid concentrations (1%, 2%, 3%, 4%, 5%) was conducted. The key findings of the study are as follows:

> **Enhanced efficiency:** The incorporation of TiO<sub>2</sub>/water nanofluids resulted in marked improvements in the efficiency and cooling performance of the shell and tube heat exchanger. This underscores the significant role nanofluids can play in optimizing thermal systems.

> **Negligible pressure loss:** It was observed that the utilization of nanofluids did not lead to a substantial increase in pressure loss, which highlights their practical application in improving heat exchanger performance without considerably elevating energy consumption.

> **Influence of flow rate:** The study identified the flow rate as a crucial factor impacting high-velocity flow. Nanofluids demonstrated a more pronounced effect, especially at lower velocities, emphasizing the complex interaction between fluid dynamics and nanofluid concentrations.

> **Improved fluid mixing:** At higher concentrations, nanofluids exhibited increased velocity magnitudes, particularly at the tube's curvature, indicating enhanced fluid mixing and heat transfer capabilities, vital for optimizing heat exchanger performance.

While these insights contribute valuable knowledge and support the research hypothesis, it is imperative to acknowledge certain limitations. The specificity of concentrations and materials used in this study may restrict the generalizability of the results. Additionally, not all external factors influencing heat exchanger performance were comprehensively examined.

Future research could focus on exploring a broader range of nanofluid types, concentrations, and varying nanoparticle sizes or shapes to enrich the understanding of their impact on heat exchanger efficiency. This study lays a foundation for future advancements in nanofluid-enhanced heat exchanger technologies, opening up potential applications in sectors dependent on efficient thermal transfer processes.

### Data Availability

Not applicable.

### Conflicts of Interest

The authors declare no conflict of interest.

## References

- [1] C. Yang, W. Li, and A. Nakayama, "Convective heat transfer of nanofluids in a concentric annulus," *Int. J. Thermal Sci.*, vol. 71, pp. 249–257, 2013. <https://doi.org/10.1016/j.ijthermalsci.2013.04.007>
- [2] Y. R. Sekhar, K. V. Sharma, R. Thundil Karupparaj, and C. Chiranjeevi, "Heat transfer enhancement with Al<sub>2</sub>O<sub>3</sub> nanofluids and twisted tapes in a pipe for solar thermal applications," *Procedia Eng.*, vol. 64, pp. 1474–1484, 2013. <https://doi.org/10.1016/j.proeng.2013.09.229>
- [3] A. M. Hussein, K. V. Sharma, R. A. Bakar, and K. Kadrigama, "The effect of nanofluid volume concentration on heat transfer and friction factor inside a horizontal tube," *J. Nanomater.*, vol. 2013, pp. 1–12, 2013. <https://doi.org/10.1155/2013/859563>
- [4] F. M. Ali and W. M. M. Yunus, "Study of the effect of volume fraction concentration and particle materials on thermal conductivity and thermal diffusivity of nanofluids," *Jpn. J. Appl. Phys.*, vol. 50, no. 8R, p. 085201, 2011. <https://doi.org/10.1143/JJAP.50.085201>
- [5] S. Z. Heris, T. H. Nassan, S. H. Noie, H. Sardarabadi, and M. Sardarabadi, "Laminar convective heat transfer of Al<sub>2</sub>O<sub>3</sub>/water nanofluid through square cross-sectional duct," *Int. J. Heat Fluid Flow*, vol. 44, pp. 375–382, 2013. <https://doi.org/10.1016/j.ijheatfluidflow.2013.07.006>
- [6] Z. Liu, Y. Li, and K. Zhou, "Thermal analysis of double-pipe heat exchanger in thermodynamic vent system," *Energy Convers. Manag.*, vol. 126, pp. 837–849, 2016. <https://doi.org/10.1016/j.enconman.2016.08.065>
- [7] E. Ozden and I. Tari, "Shell side CFD analysis of a small shell-and-tube heat exchanger," *Energy Convers. Manag.*, vol. 51, no. 5, pp. 1004–1014, 2010. <https://doi.org/10.1016/j.enconman.2009.12.003>
- [8] M. H. Shedid, "Computational heat transfer for nanofluids through an annular tube," in *Proceedings of the International Conference on Heat Transfer and Fluid Flow, Prague, Czech Republic*, 2014, pp. 206–212. <https://doi.org/10.13140/2.1.2343.1040>
- [9] S. Asadbeigi, E. Ahmadi, M. Goodarzi, and A. Sagharichian, "Analyzing and simulating heat transfer and designing a shell and tube heat exchanger for the pasteurization process of tomato paste: A CFD study," *Heliyon*, vol. 9, no. 11, p. e21593, 2023. <https://doi.org/10.1016/j.heliyon.2023.e21593>
- [10] Y. Wu, J. C. Rong, D. Wang, X. F. Zhao, L. Meng, M. Arıcı, C. Y. Liu, R. T. Yang, and D. Li, "Synergistic enhancement of heat transfer and thermal storage characteristics of shell and tube heat exchanger with hybrid nanoparticles for solar energy utilization," *J. Clean Prod.*, vol. 387, p. 135882, 2023. <https://doi.org/10.1016/j.jclepro.2023.135882>
- [11] A. Abidi and S. M. Sajadi, "Numerical assessment of hydraulic behavior and thermal efficiency of multiphase hybrid nanofluid in a shell-and-tube heat exchanger with inclined baffles," *Eng. Anal. Bound Elem.*, vol. 156, pp. 114–125, 2023. <https://doi.org/10.1016/j.enganabound.2023.08.002>
- [12] S. Han, X. Li, Z. Liu, B. Zhang, C. He, and Q. Chen, "Thermal-economic optimization design of shell and tube heat exchanger using an improved sparrow search algorithm," *Therm. Sci. Eng. Prog.*, vol. 45, p. 102085, 2023. <https://doi.org/10.1016/j.tsep.2023.102085>
- [13] M. Linda, A. Agarwal, and P. Sinha, "Computational fluid dynamics analysis of vertical axis wind turbine heights for enhanced hydrogen production in urban environments," *J. Intell. Syst. Control*, vol. 2, no. 3, pp. 123–131, 2023. <https://doi.org/10.56578/jisc020301>
- [14] A. Agarwal and L. Mthembu, "FE structural analysis and experimental investigation of HMV chassis," in *Emerging Trends in Mechanical and Industrial Engineering: Select Proceedings of ICETMIE 2022*, 2023, pp. 931–943. [https://doi.org/10.1007/978-981-19-6945-4\\_70](https://doi.org/10.1007/978-981-19-6945-4_70)
- [15] A. Agarwal, M. T. Letsatsi, and I. Pitso, "Response surface optimization of heat sink used in electronic cooling applications," in *Recent Advances in Materials and Modern Manufacturing: Select Proceedings of ICAMMM 2021*, 2022, pp. 121–129. [https://doi.org/10.1007/978-981-19-0244-4\\_13](https://doi.org/10.1007/978-981-19-0244-4_13)
- [16] F. R. Menter, "Two-equation eddy-viscosity turbulence models for engineering applications," *AIAA J.*, vol. 32, no. 8, pp. 1598–1605, 1994. <https://doi.org/10.2514/3.12149>