



# Harnessing Social Capital for Fostering Non-Tourism Actor Involvement in Sustainable Tourism: A Case Study of an Indonesian Village



Rahmawati Rahmawati<sup>1</sup>, Gunawan Prayitno<sup>1\*</sup>, Nailah Firdausiyah<sup>1</sup>, Dian Dinanti<sup>1</sup>, Ainul Hayat<sup>2</sup>, Achmad Efendi<sup>3</sup>, Matt Roskrug<sup>4</sup>

<sup>1</sup> Regional and Urban Planning Department, Faculty of Engineering, Brawijaya University, 65145 Malang, Indonesia

<sup>2</sup> Educational Administration Study Program, Faculty of Administrative Sciences, Brawijaya University, 65145 Malang, Indonesia

<sup>3</sup> Department of Statistics, Faculty of Mathematics and Natural Sciences, Brawijaya University, 65145 Malang, Indonesia

<sup>4</sup> School of Economics and Finance, Massey Business School, Massey University, 0632 Auckland, New Zealand

\* Correspondence: Gunawan Prayitno ([gunawan\\_p@ub.ac.id](mailto:gunawan_p@ub.ac.id))

**Received:** 05-04-2023

**Revised:** 06-07-2023

**Accepted:** 06-14-2023

**Citation:** R. Rahmawati, G. Prayitno, N. Firdausiyah, D. Dinanti, A. Hayat, A. Efendi, and M. Roskrug, "Harnessing social capital for fostering non-tourism actor involvement in sustainable tourism: A case study of an Indonesian village," *J. Urban Dev. Manag.*, vol. 2, no. 2, pp. 69–83, 2023. <https://doi.org/10.56578/judm020202>.



© 2023 by the author(s). Published by Acadlore Publishing Services Limited, Hong Kong. This article is available for free download and can be reused and cited, provided that the original published version is credited, under the CC BY 4.0 license.

**Abstract:** As tourism village development proliferates in Indonesia, discernible disparities in perceived benefits among tourism and non-tourism stakeholders have been noted, suggesting that the advantages of tourism are not uniformly distributed among the community. Here, social capital, representing interpersonal trust, networks, and shared norms, emerges as a significant catalyst for resolving the identified challenges and securing community endorsement for sustainable village tourism. This investigation aims to explore the role of social capital and the extent of non-tourism actor engagement in facilitating the longevity of a selected Indonesian tourism village. Data concerning social capital and community involvement were procured via questionnaires administered to 270 respondents, the majority of whom were non-tourism actors within the village. The collected data were subsequently scrutinised utilising Structural Equation Modelling (SEM). The study found that while these non-tourism actors are primarily of productive age, their education levels are relatively low and their primary occupations are low-income farming. Intriguingly, these individuals demonstrate substantial social capital despite their lack of direct engagement in tourism activities, which could be harnessed to promote their active involvement in sustainable village tourism. The research further underscores that trust, a fundamental facet of social capital, is instrumental in cultivating community networks and promoting active participation among non-tourism actors. The understanding derived from this research is hoped to provide a basis for policy formulation, aimed at fostering non-tourism actor engagement in tourism-centric activities, thereby allowing them access to the tourism industry benefits, such as secondary income through tourism-related jobs.

**Keywords:** Social capital; Participation; Tourist village; Benefits; Non-tourism actors, Indonesia

## 1 Introduction

Tourism villages, a rapidly growing trend, have emerged as vital components in sustainable, community-based rural tourism development [1]. The success of these villages is heavily reliant on the acceptance and endorsement of their presence by local communities [2]. The significance of local communities cannot be understated; they are paramount recipients of the impacts of this form of development [3].

The creation of a tourist village demands an investment of various types of capital, of which social capital stands out as essential [4]. In social interactions and engagements, social capital forms the cornerstone [5]. Its role is indispensable in guiding behaviour and swaying others to act [6]. Encouraging community participation, it is a catalyst in enhancing tourism development [2]. It underlies the perception of individuals that tourism can offer them benefits, which can subsequently stimulate community engagement in supportive actions and collaborative efforts [7].

Roles of local communities in the advancement of tourism villages are two-fold. Some inhabitants become tourism actors, directly supporting the development by becoming workforce or managers. Conversely, those not involved directly play their part by maintaining the social order, preserving the cultural heritage, safeguarding the environment, and ensuring the safety and comfort of the village. Their actions aim to attract repeated tourist visits [8].

In the fusion of tourist attractions with the local culture and social conditions, a unique blend emerges, forming the essence of tourism villages [9]. Providing a satisfactory tourist experience hinges on the creation of an appealing environment and positive impressions [10]. At their core, tourism villages are agricultural communities with unique resources that can be converted into distinctive tourist attractions without jeopardizing the authentic village characteristics. These villages can spur sales of agricultural products and, in turn, boost the local economy [11, 12]. Hence, fostering a congenial social environment conducive to hospitality becomes critical in promoting tourism and encouraging return visits [13].

One such success story unfolds in Pujon Kidul Tourism Village in East Java Province, Indonesia, which has proficiently capitalized on its agricultural potential to evolve into a tourist village [14]. This village attained a sustainable tourism certification in 2020. The leading forces behind this transformation were members of the local tourism awareness group, Pokdarwis. They employed a unique agricultural-based tourism development concept, the hallmark of which is Cafe Sawah. This cafe, offering visitors a rural ambiance, serves a variety of dishes prepared from local agricultural produce [15]. Despite its success, not all local community members are involved in managing the village. The management falls under BUMDes (Village Owned Enterprises), resulting in community discontent regarding unequal benefits. Previous research by Ira and Muhamad [16] pointed out the disparity in community participation, although the overall condition was deemed good with 200 tourism actors. This number, however, saw a decrease to 192 in 2021 (data from BUMDes Employees in Pujon Kidul Tourism Village, 2021). Field conditions further reveal that less than 10% of the total population of 4,341 people or 1,250 households participate in the village's tourism activities, indicating a majority remains uninvolved. It has been observed that the community plays either of two roles: as tourism actors or non-tourist contributors. The challenge lies in effectively engaging more members of the community for a more balanced and sustainable tourism model.

In the landscape of tourism, disparities in benefit distribution can often be observed. The differences in the advantages accrued from tourism hinge largely on the roles that individuals play within this sector. Those uninvolved in tourism, or 'non-actors', may not necessarily reap the benefits due to their lack of participation. On the other hand, actors engaged directly in tourism-related activities are, predictably, more likely to benefit from this industry, as their involvement leads to increased welfare and income [15].

A paradigmatic case of this can be observed in tourist villages, where the benefit distribution is typically skewed. The majority of benefits are often pocketed by individuals directly linked with the tourism industry, such as business owners and members of tourism-awareness groups [15]. An increase in proximity to tourism locations is also frequently correlated with greater benefits. This advantage often materializes in the form of entrepreneurial opportunities linked to the tourism sector [17].

However, this uneven distribution of benefits may engender societal conflict, rooted in feelings of resentment and jealousy [18]. To alleviate such disparities, it is vital to increase the involvement of local communities [19]. Bridging the societal gaps and preventing divisions from deepening necessitate the implementation of effective social solutions [20].

In this context, social capital emerges as an indispensable tool. It enables communities to address prevailing issues more effectively by fostering a sense of awareness, unity, and participation among its members [6, 7]. The transition from viewing community participation as a mere obligation to understanding it as a right for all community members is crucial [21]. This participation spans four key stages: planning, implementation, utilization, and evaluation.

This investigation pivots around the stage of utilization, aiming to determine the degree to which community members have benefitted from implemented tourism programs. Active community participation at this stage entails making use of the program's outcomes and contributing towards the operation and maintenance of these benefits, thereby ensuring sustainability [22]. For any tourism program to be sustainable, acceptance and support from the community are essential. It is often observed that communities face challenges in accepting new initiatives, typically due to lack of knowledge or information about the program's workings [23, 24].

Understanding the extent to which a tourism program can contribute positively to the community, without disrupting its harmony, is critical. This research aims to evaluate the potential for non-actors in the Pujon Kidul Tourism Village to contribute to tourism through their social capital and to assess the role of tourism in engaging non-actors in sustainable development initiatives.

This research holds potential to contribute significantly to the theoretical understanding of social capital and the participation of non-tourist communities, particularly at the utilization stage. It is anticipated that the findings will inform policy formulation for the development of the Pujon Kidul Tourism Village, fostering opportunities and benefits for the entire community.

## 2 Methodology

The transformation of Pujon Kidul Village into a thriving tourist hub (Figure 1), serves to highlight the community and village benefits that can be derived from successful tourist villages. Opportunities for new businesses and employment are created within these villages, contributing to the economic upliftment of the region. The Pujon Kidul Tourism Village, a scenic panorama encompassing lush green expanses of rice fields (Figure 2), is renowned for its calming ambiance, enhanced by the gentle, refreshing breeze, a key attraction for tourists.

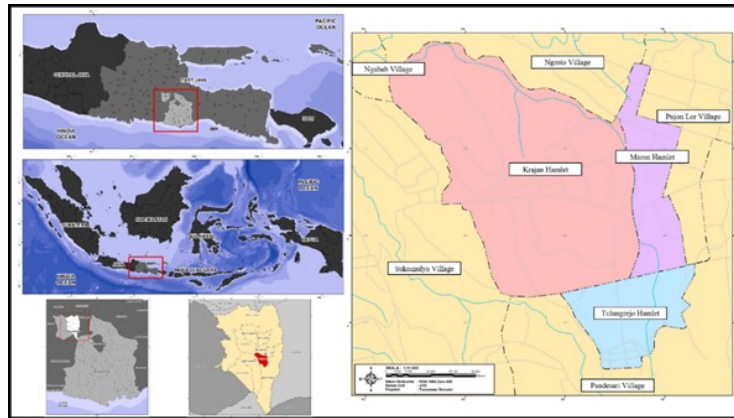

**Figure 1.** Pujon Kidul Tourism Village map

Note: This figure was prepared by the authors.



**Figure 2.** Scenery of Pujon Kidul Tourism Village

Note: This figure was prepared by the authors.

The research methodology employed in this study was a quantitative approach, designed in line with the objectives of the research. The research variables employed (Figure 3) include social capital variables and community participation variables, focused on the utilization stage. The specific flow of the research can be viewed in Figure 4.

Data for this research was collected through both primary and secondary surveys. The population comprised 1,250 family heads within the Pujon Kidul Village, a selection based on the concept that social capital is essentially formed within the family unit, and subsequently extends to the surrounding community [25]. Furthermore, social capital is intrinsically linked to internal community ties, including family, friends, neighbors, or groups with shared objectives [26].

The sample size was strategically determined to achieve a proportional representation of the entire Pujon Kidul Village community. The use of proportional random sampling, in tandem with subsequent proportion calculations across the three hamlets of the Pujon Kidul Tourism Village, ensured an even distribution of the population representation. The Isaac and Michael Table was utilized to determine the sample size, with a 5% margin of error, resulting in a sample of 270 families, distributed across the three hamlets.

Questionnaires were employed to collect data, featuring questions based on indicators for each variable. In total, 21 questions were included in the questionnaire, divided amongst the variable trust (5 questions), the norm variable (3 questions), the network variable (5 questions), and the community participation variable (3 questions). These questions were measured using a Likert scale of 1-5. Prior to the distribution of the questionnaires, a preliminary survey and literature review were conducted to facilitate the development of the questionnaire, based on the characteristics of the Pujon Kidul Tourism Village community.

SEM AMOS [27] was employed for data analysis, an efficient statistical tool for managing concurrent stratification models. This approach includes two stages of analysis, namely the analysis of the measurement model and the

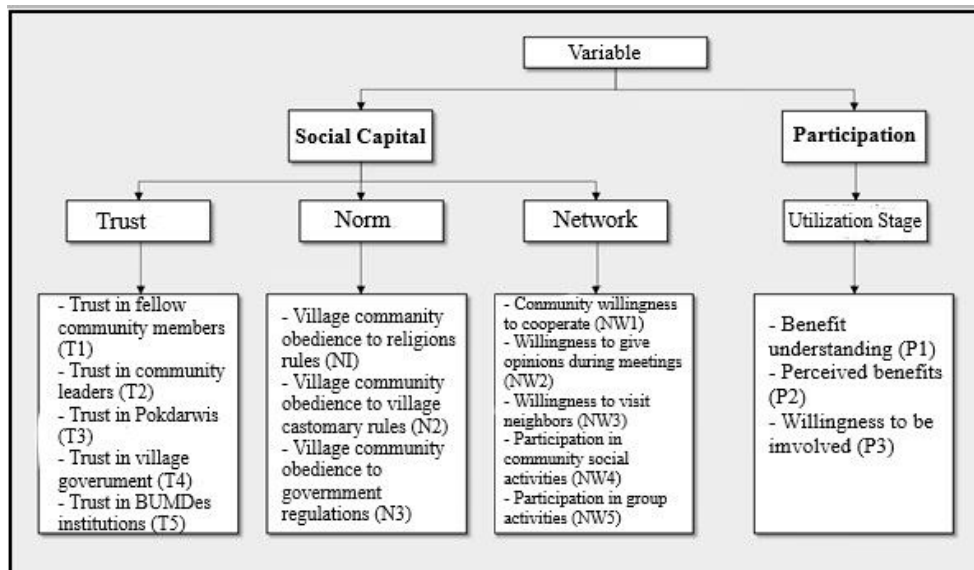

**Figure 3.** Research variables

Note: This figure was prepared by the authors.

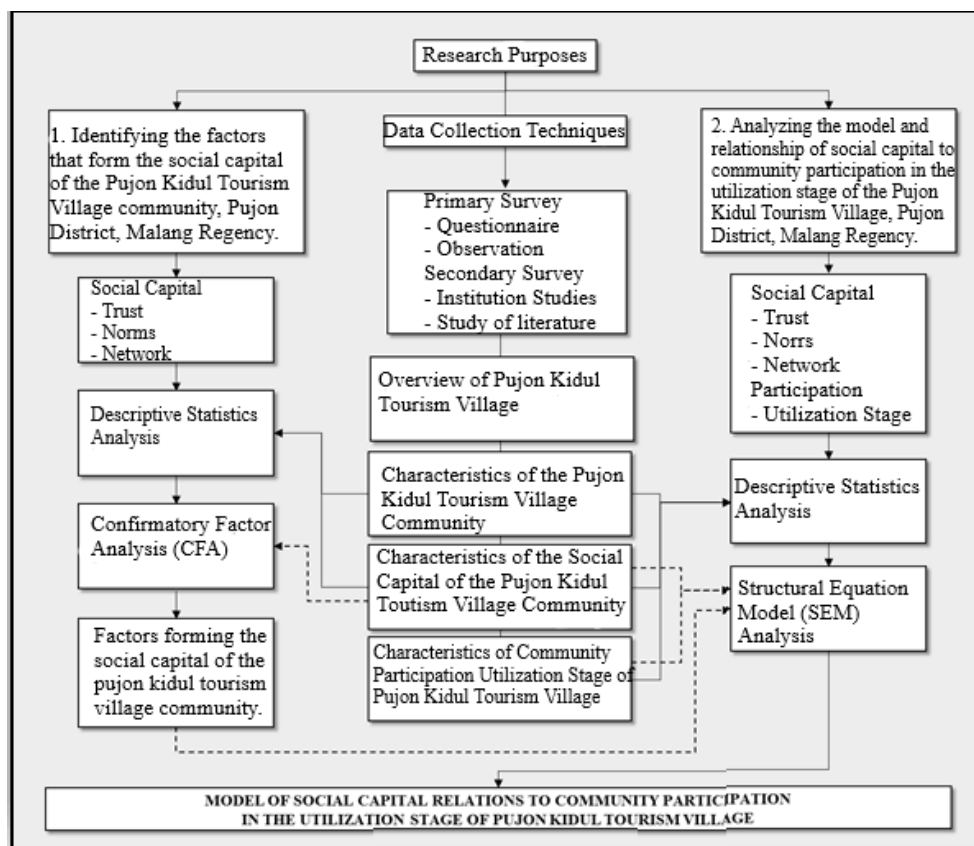

**Figure 4.** Flowchart of research methods

Note: This figure was prepared by the authors.

structural model. The first stage involved confirmatory factor analysis (CFA) to examine the validity and reliability of the indicators forming the construct variable or the second latent variable (trust, norms, and networks). A model was considered feasible if it satisfied at least 4 to 5 goodness of fit criteria [27]. Following the validation of a feasible CFA model, SEM analysis was conducted. This research utilized Covariance-Based SEM or CB-SEM analysis with the latent variable consisting of social capital, and the second latent variable including trust, norms, and networks.

It is important to note that this study incorporated the Maximum Likelihood Estimation technique due to the 270

samples used. Therefore, the CFA analysis conducted in this research was a second order CFA test.

### 3 Results

#### 3.1 Results of Characteristics of Respondents Not Tourism Actors

The present analysis encompasses the characteristics of 270 respondents, specifically those who are not directly engaged in tourism-related activities. This examination is integral for establishing potential strategies for mobilizing community participation in programs conducive to the demographics of the non-tourism community, thereby indirectly contributing to the sustainability of the Pujon Kidul Tourist Village [28].

Primarily, the characteristics of non-tourism actors were evaluated based on age and segmented into 12 categories, each representing a five-year range. A significant majority of respondents (96%, n=259) were found within the productive age bracket of 15 to 64 years, highlighting a substantial potential for non-tourism actors to partake in tourism-related development in the village.

Moreover, the respondents were also divided into five categories according to education level, with each subgroup denoting the typical divisions of educational attainment within Indonesia. It was observed that 75% (n=202) of the respondents only completed primary education. This prevalence of low education levels among non-tourism actors suggests a necessity for tailored guidance to stimulate innovation and problem-solving capabilities, hence facilitating their involvement in the village's tourism sustainability.

The respondents were further categorized based on employment type into six divisions, including farm workers, farmers, civil servants, private employees, employee entrepreneurs, and entrepreneurs. The majority were employed as farm workers (49%, n=132) or farmers (19%, n=52). This data signifies that the largest segment of non-tourism actors are significantly detached from tourism-related activities due to the nature of their occupations, underlining the need for specific strategies to integrate these individuals into tourism-related development initiatives.

Finally, respondents were classified into three groups according to income: those earning below, equivalent to, or above the Regional Minimum Wage (RMW) of Malang Regency [Rp 3.068.275]. A considerable proportion of respondents (77%, n=209) had an income below RMW, reinforcing the requirement for strategic planning to engage non-tourism actors in activities promoting the sustainability of Pujon Kidul Tourist Village, which could provide them with supplementary income to fulfil their needs.

In summary, this assessment provides critical insights into the characteristics of non-tourism actors within the Pujon Kidul community. Despite not being directly involved in tourism activities, the potential for their engagement, especially those in productive age groups, those with lower educational attainment, and those with income below RMW, is noteworthy. The findings suggest the importance of developing targeted strategies to mobilize this substantial sector of the community to support the village's tourism sustainability.

#### 3.2 Results of Characteristics of Elements of Social Capital

The research captured responses from a cohort of 270 individuals, utilizing a 13-question survey representing all social capital indicators. The 5-point Likert scale, extending from Totally Disagree (TD) to Totally Agree (TA), was employed to gather the responses. It was discerned that respondents mostly exhibited agreement or total agreement across all social capital sub-variables.

##### 3.2.1 Trust

In this category, five indicators were established, and responses were collected from all participants. In relation to their immediate neighbors, 85% of respondents demonstrated trust, a sentiment indicated by a propensity towards mutual aid, both material and service-oriented, and sustained familiarity [Figure 5, Trust (T1)]. Faith in village community leaders was found in 69% of the respondents, with trust based on community leaders' longstanding residency and visibility within the village [Figure 5, Trust (T2)]. Confidence in Pokdarwis was reported by 74% of respondents. This level of trust, it was determined, stems from the organization's engagement with the community and its elected member's transparency [Figure 5, Trust (T3)]. Trust in the village government was declared by 88% of the respondents. This faith was believed to be due to equitable treatment by the government and their visible efforts in village development [Figure 5, Trust (T4)]. Lastly, the BUMDes institution was trusted by 71% of the respondents, reflected in the effective management of village resources and engagement with the community [Figure 5, Trust (T5)].

##### 3.2.2 Norm

Three indicators were identified under this category. A significant majority (80%) of respondents agreed on the importance of adhering to religious rules. Such adherence was expressed through obedience to both formal and informal religious laws [Figure 6, Norm (N1)]. Customary rules were respected by 69% of respondents, as indicated by their compliance to both written and unwritten community traditions [Figure 6, Norm (N2)]. Government regulations, on the other hand, were acknowledged by 63% of respondents, identified by their willingness to comply with village governance [Figure 6, Norm (N3)].

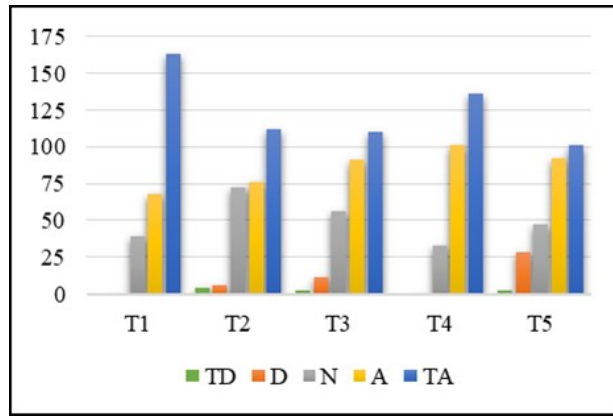

**Figure 5. Trust**

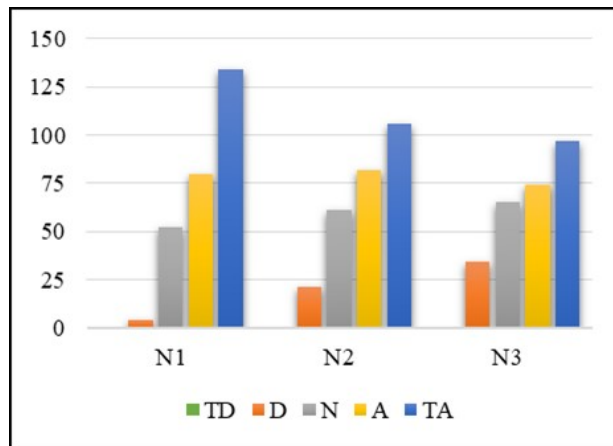

**Figure 6. Norm**

### 3.2.3 Network

Five indicators were formed within this category. A notable 90% of respondents deemed it essential to cooperate with the village community, evidenced by a readiness to work towards shared goals [Figure 7, Network (NW1)]. Equal importance was given to voicing opinions in community meetings, with 90% of respondents recognizing this as a key aspect of citizen participation [Figure 7, Network (NW2)]. A majority of respondents (71%) also expressed willingness to visit neighbors, underscoring their interest in information exchange and community concern [Figure 7, Network (NW3)]. Participation in social activities was found to be valued by 62% of respondents, seen as a means to strengthen community ties and access information [Figure 7, Network (NW4)]. Finally, 72% of respondents indicated participation in group activities, emphasizing the perceived importance of building relationships and gaining potential advantages [Figure 7, Network (NW5)].

These results depict a nuanced view of social capital in the context of this particular village, with varying levels of trust, adherence to norms, and network participation shaping community dynamics. Such insights can be valuable in informing the development and implementation of policies and initiatives aimed at furthering village growth and prosperity, especially within the sphere of tourism.

### 3.3 Results of Participation Stage Utilization Characterization

The utilization stage of participation was examined through three main questions, each aiming to assess different aspects of community involvement in tourist villages. Figure 8 provides visual insight into the responses of the 270 surveyed individuals.

In assessing the comprehension of tourism village benefits (P1), it was discovered that 57% of the respondents displayed an understanding of these benefits, with an additional 32% possessing neutral to sufficient knowledge. Recognition of these benefits is crucial for the development and sustainability of tourist villages, as indicated by the perceived community advantage from improved road infrastructure as a result of tourism. It is speculated that the understanding of such benefits might extend to the daily convenience offered by quality roads.

Further inquiry was made into the tangible benefits experienced by community members (P2) following the

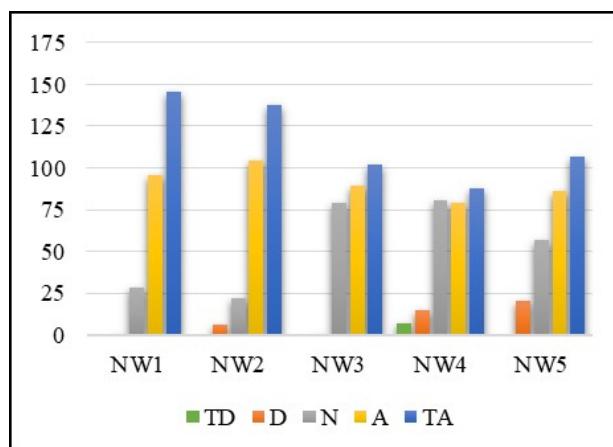

Figure 7. Network

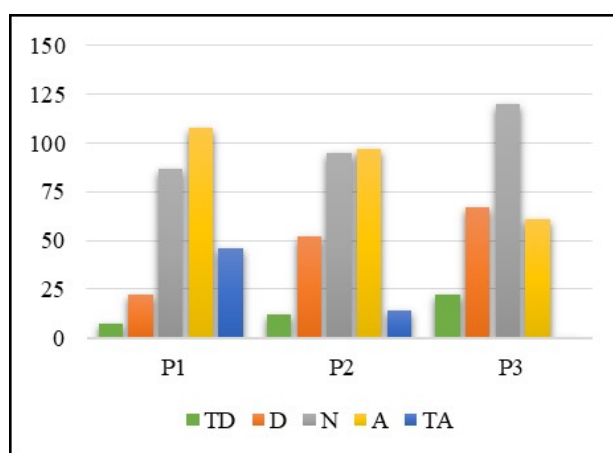

Figure 8. Community participation

establishment of tourist villages. The results showed a 41% affirmative response, complemented by a 35% neutral to sufficient acknowledgement of these benefits. The positive impacts, such as infrastructural improvements and cooperative enhancements, were reported to contribute significantly to village life. A specific case was noted in the Pujon Kidul Tourist Village, where increased recognition and additional funds were apparent outcomes of tourism.

In order to gauge the willingness of individuals to contribute to the preservation of tourist villages (P3), a third question was posed. The data showed a comparatively lower willingness rate at 23%, with a neutral to sufficient willingness at 44%, and a 33% reluctance to be involved. Although the correlation between understanding and experiencing the benefits of tourism with the willingness to contribute to its sustainability was anticipated, the data did not fully support this hypothesis. The reasons behind such reticence to participate, despite awareness and personal benefits, may warrant further exploration.

### 3.4 CFA on Social Capital: Procedure and Results

This study incorporated a two-stage Confirmation Factor Analysis (CFA) as part of the Structural Equation Modeling (SEM), also known as Covariance-Based SEM or CB-SEM, in line with the existing theory of social capital. The two categories of social capital variables in this analysis were: the primary latent variable (social capital) and secondary latent variables (trust, norms, and networks). The latter served as the measuring parameter for the former, justifying the application of a second-order CFA test.

During the initial phase of the CFA, each indicator of the secondary latent variable was evaluated for significance, with the threshold set at a CR value [ $\geq 1.967$ ] and a P value [ $\leq 0.05$ ], denoted by \*\*\* or a significance level of 0.001. Validity was affirmed when the Loading Factor value was [ $\geq 0.50$ ]. Indicators failing to meet these criteria were disregarded, and the model's fitness was also evaluated. A model was deemed feasible upon fulfilling four to five 'goodness of fit' criteria.

The secondary stage of the CFA was executed after eliminating the invalid indicators from the initial stage [K2, K3, J2, J3, and J4]. The second stage of CFA served as the basis for subsequent SEM analysis, and the results are

illustrated in Figure 9.

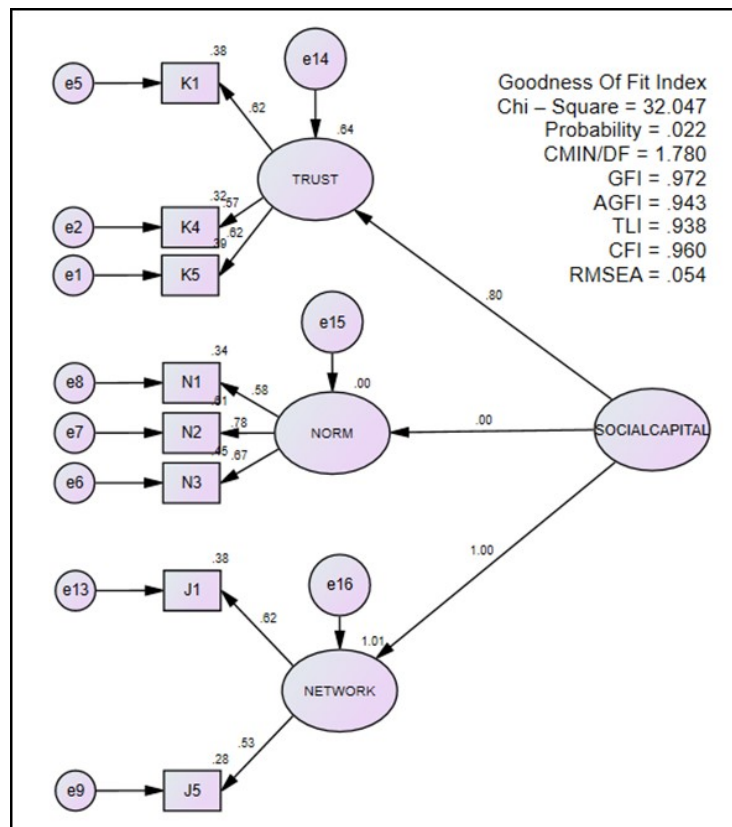

Figure 9. SEM model

Tables 1-2 depict the findings from the significance and validity tests of the CFA model and the CFA model fit test, respectively. Upon computation, all eight indicators were confirmed as significant and valid, denoting successful measurement of the secondary latent variables (trust, norms, and networks). Moreover, no indicators were discarded during this phase. The final CFA model passed seven 'goodness of fit' criteria, as per Table 2, suggesting a robust model. Consequently, the resulting trust variables comprised of K1, K4, and K5, the norms variables were N1, N2, and N3, and the network variables were J1 and J5.

Table 1. Results of significance test and validity test of CFA model

Variable	Sub var	C.R	P	Loading factor	Information
Trust	K1	6.425	***	0.618	Valid
	K4	6.205	***	0.568	Valid
	K5	Fixed		0.625	Valid
Norm	N1	7.174	***	0.583	Valid
	N2	6.968	***	0.780	Valid
	N3	Fixed		0.668	Valid
Network	J1	5.132	***	0.618	Valid
	J5	Fixed		0.531	Valid

### 3.5 SEM Analysis: Procedures and Results

Upon establishing a fit model through the second stage of the Confirmation Factor Analysis (CFA), an in-depth exploration of the relationship between social capital and community participation was undertaken, facilitated by Structural Equation Modeling (SEM) analysis. The SEM analysis specifically targeted community participation at the utilization stage within the Pujon Kidul Tourism Village. The selection of the most appropriate model was of utmost importance. Within this research context, three models were hypothesized to accurately portray the relationship between the variables of social capital and participation. The selection of the best fitting model hinged



**Table 2.** CFA model fit test results

Goodness of fit index [cut off value]	Results	Information [Good Fit (GF)/ Poor Fit (PF)]
Chi-square [ $< \alpha$ .df( $\alpha = 0.005$ )]	32.047[ $< df = 18 = 37.1564$ ]	GF
Probability [ $\geq 0.05$ ]	0.022	PF
AGFI [ $\geq 0.90$ ]	0.943	GF
CMIN/DF [ $\leq 2.00$ ]	1.780	GF
CFI [ $\geq 0.90$ ]	0.960	GF
GFI [ $\geq 0.90$ ]	0.972	GF
RMSEA [ $\leq 0.08$ ]	0.054	GF
TLI [ $\geq 0.90$ ]	0.938	GF

on the fulfilment of good fit criteria. Upon analysis, it was determined that Model 3 displayed optimal fitness and significance in characterizing the link between social capital and community participation. Within Model 3, the variable of trust was found to have a direct association with the network variable, which, in turn, directly influenced the community participation variable at the utilization stage in the Pujon Kidul Tourism Village. The hypothesis for the three models are delineated as follows:

(1) Model 1: Hypothesis stipulates a direct correlation between norms and network variables, which, in turn, directly impacts trust and participation.

(2) Model 2: Hypothesis suggests a direct correlation between network variables and trust, which, in turn, directly influences norms and participation.

(3) Model 3: Hypothesis proposes a direct correlation between belief and norm variables, which, in turn, directly impacts the network and participation.

The results of the SEM model significance and fit test are summarized in Table 3 and Table 4, respectively. Figure 10 provides a graphical representation of the SEM model.

**Table 3.** SEM model significance test results

Path coefficient	C.R.	P	Loading factor	Information
Trust → Network	5.621	***	0.915	Significant
Norm → Network	2.243	0.025	0.21	Not Significant
Network → Participation	5.269	***	0.552	Significant
Norms ↔ Trust	-0.624	0.533	-0.056	Not Significant

**Table 4.** SEM model fit test results

Goodness of fit index [cut off value]	Results	Information [Good Fit (GF)/ Poor Fit (PF)]
Chi-square [ $< \alpha$ .df( $\alpha = 0.005$ )]	70.106[ $< df = 40 = 66.76$ ]	PF
Probability [ $\geq 0.05$ ]	0.002	PF
AGFI [ $\geq 0.90$ ]	0.926	GF
CMIN/DF [ $\leq 2.00$ ]	1.753	GF
CFI [ $\geq 0.90$ ]	0.951	GF
GFI [ $\geq 0.90$ ]	0.995	GF
RMSEA [ $\leq 0.08$ ]	0.053	GF
TLI [ $\geq 0.90$ ]	0.933	GF

An examination of Table 3 highlights significant and insignificant path coefficients within the SEM model. Significance in a model is confirmed when it exhibits a CR value [ $\geq 1.967$ ] and a P value [ $\leq 0.05$ ], which are denoted by \*\*\*. A significant path coefficient implies mutual influence of the variables within the pathway. The model denotes two insignificant path coefficients, namely, the relationship of norms to the network, and norms to trust. Significant path coefficients include the relationship of trust to the network and the network to participation.

A model is considered feasible if it meets at least four to five 'goodness of fit' criteria. Based on these parameters, the SEM model can be deemed feasible, as it meets six criteria, as summarized in Table 4. Figure 10 presents a visual representation of the relationship between social capital and community participation in the model, thereby

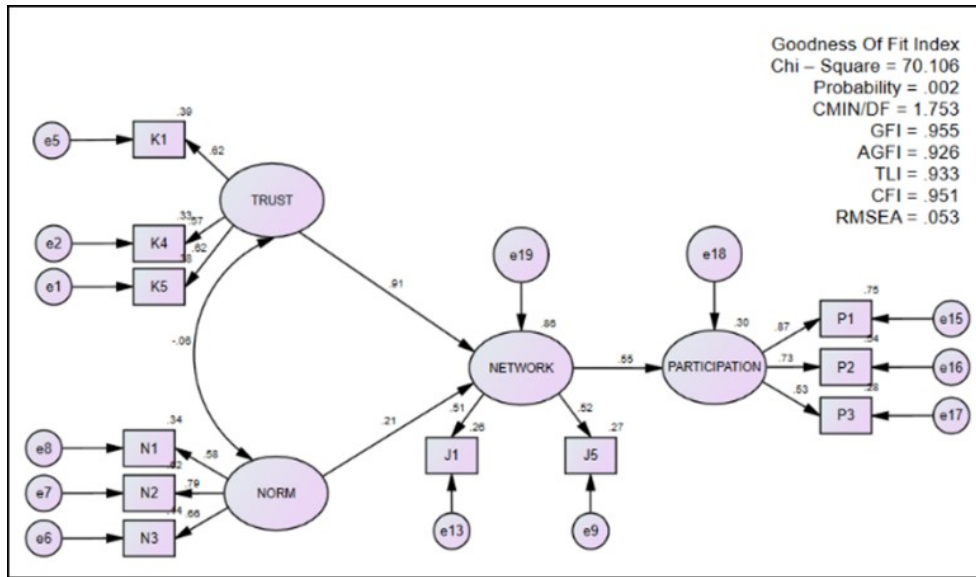

Figure 10. SEM model

indicating a direct link between trust and network variables, and between network and community participation variables at the utilization stage in the Pujon Kidul Tourist Village (refer to Table 5).

Table 5 depicts the Squared Multiple Correlation (R<sup>2</sup>) of the SEM model, which provides insight into the influence of the relationship between social capital variables with their three dimensions and participation variables. The data revealed that the trust variable, as held by the Pujon Kidul Tourism Village community, positively impacted the network variable by 0.859 or 85.9%. Additionally, the established network within the Pujon Kidul Tourism Village community relations positively impacted the participation variable by 0.304 or 30.4%. This outcome can be interpreted as follows: a high level of trust within the Pujon Kidul Tourism Village community enhances the establishment of a robust network within the community relations. An improved network subsequently amplifies community participation, thereby endorsing the sustainability of the Pujon Kidul Tourism Village.

Table 5. Squared multiple correlations SEM model

Squared multiple correlations	Estimate
Network	0.859
Participation	0.304

## 4 Discussion

### 4.1 Discussion of Characteristics of Respondents, Social Capital, and Participation Stage Utilization

Reflecting on the characteristics of the respondents within the Pujon Kidul Tourism Village study, it has been observed that a majority have achieved low levels of formal education. This observation corroborates the findings of [29], suggesting that individuals with lower educational attainment tend to display greater trust in others. This increased trust can be attributed to their limited knowledge base, leading to a reliance on individuals who have been part of their lives for extended periods, or those who possess a higher educational background.

The unique social structure of the village community, characterized by close kinship and longstanding relationships, greatly contributes to this trust-building process. These societal characteristics create an environment conducive to communal care, cooperation, and adherence to established norms aimed at communal welfare. The societal structure of Pujon Kidul Tourism Village exemplifies this pattern, where the majority conform to societal norms and actively engage in communal activities. This corroborates [30], stating that village communities are often synonymous with high levels of socialization, which fosters a willingness to participate in community events for strengthening kinship and collective success.

Assessing the social capital of the Pujon Kidul Tourism Village community in terms of trust, norms, and networks, reveals a positive status quo. Evidence from the responses gathered in the study shows that a significant proportion strongly agree that the current condition of their social capital is in good shape and plays an instrumental role in their everyday life. This network of trust and norms within the community contributes significantly to the unique social

capital of the village, making it a cornerstone for most communal activities, including traditional, social, and group initiatives. The respondents' willingness to participate in these activities is fundamentally based on this high trust, which correlates with study [31] emphasizing that trust is a fundamental component of social capital. Absence of trust, as study [32] contends, can impede the development of robust relationships within a network. In the current favorable conditions, this social capital, which is not exclusive to tourism actors, forms the foundational potential encouraging community participation in the sustenance of the Pujon Kidul Tourism Village.

The utilization phase of the Pujon Kidul Tourism Village displays a relatively favorable state of community participation. Despite the overall lack of understanding and clear benefits related to tourism villages, the community shows a willingness to contribute to their sustainability. Their involvement is largely predicated on the anticipated benefits and perceived importance of these initiatives. The primary deterrent for community involvement stems from a lack of understanding of the potential benefits of a tourist village. The opportunity for involvement in tourism development and employment within the tourism industry is much higher for members of the Pokdarwis within the Pujon Kidul Tourism Village community. Conversely, those not affiliated with the Pokdarwis face limitations. This supports the observation by study [33] that group involvement provides greater opportunities for relationship building and benefit realization at both individual and group levels compared to non-involvement.

As such, it can be argued that the Pujon Kidul Tourism Village community's social capital and participation in the utilization stage are intrinsically linked, influenced by their societal norms, trust networks, and educational backgrounds. This analysis emphasizes the need for further research into the dynamic relationship between social capital and community participation in rural tourism development and sustainability.

Further studies may also delve into the possible interventions aimed at enhancing community understanding of the benefits of tourist villages and strategies to broaden participation, especially among non-Pokdarwis members. This could entail education initiatives, community engagement programs, and targeted efforts to bolster social capital within these communities. Such efforts could potentially unlock the latent potential within these communities, contribute to the sustainability of tourism villages, and foster community development.

#### **4.2 Discussion of CFA and SEM Analysis of the Social Capital and Participation**

The Confirmatory Factor Analysis (CFA) elucidates the constituting factors of each dimension of social capital variable. Primarily, three elements shape the trust variable, viz., (T1), (T4), (T5). Of these, it has been discerned that Trust in the BUMDes Institution (T5) is the most influential, exhibiting a loading factor value of 0.625. The high trust in BUMDes has been attributed to its efficacious management of village potential [34].

The norm variable, in contrast, has been seen to be shaped by three different factors (N1), (N2), (N3). The most significant among these is the Village community obedience to village customary rules (N2), possessing the highest loading factor value of 0.780 [35]. In the Pujon Kidul Tourism Village community, the network variables are influenced by two factors: (NW1) and (NW5). Of these, the Community Willingness to cooperate (NW1) has been found to possess the highest loading factor value of 0.618 [36].

The Structural Equation Modelling (SEM) analysis helps in identifying the relationships of social capital to community participation at the utilization stage in Pujon Kidul Tourism Village. According to the findings, Model 3 is the most suitable to explain this relationship. The trust variable in Model 3 positively impacts the network variable, with an effect value of 0.859 or 85.8%. Simultaneously, the network variable impacts the participation variable, with an effect value of 0.304 or 30.4%.

Therefore, there is a positive correlation of 85.8% between the trust variable and the network variable. As trust increases, the network becomes more robust. Similarly, there is a positive correlation of 30.4% between the network variable and the community participation variable. A better network equates to higher community participation.

It can thus be inferred that the level of trust within the Pujon Kidul Tourism Village community significantly influences the quality of the network formed. Subsequently, the quality of this network influences community participation levels. This sequence of interactions presents a cascading effect of trust on participation via the networking element of social capital, indicating the intricate interplay between these variables. The findings hold relevance in policy formulation, particularly in the context of community-based tourism ventures, as they underscore the importance of fostering trust and networking within communities.

This Discussion section of the study has been rephrased in a passive voice and edited for clarity and flow, as per the guidelines of top academic journals such as Nature and Science:

The study has demonstrated that trust is the cornerstone of social capital within non-tourism actors of the Pujon Kidul Tourism Village. A high level of trust within a community is posited to pave the way for increased cooperative ventures, as it forms the foundation of social capital [21]. It has been posited that the ease of initiating cooperation, coordination, and other activities is predicated on the existence of trust within the community. The existence of trust is also noted to stimulate proactive action, defined as the group members' fervent desire to not only be involved but also seek ways to actively participate in community activities [37].

For non-tourism actors within the Pujon Kidul Tourism Village, their trust forms the basis of cooperative

establishment and facilitates the achievement of program objectives. Within the context of community-based tourism, such as in the Pujon Kidul Tourism Village, the significance of trust between community members cannot be overstated. The presence of collective agreements within communities is directly tied to the mutual trust of the local people. In the absence of trust, it is feared that suspicion and opportunistic behavior may proliferate, resulting in increased discord among community members. However, trust, founded on high norms of reciprocity, has been found to efficiently counteract opportunism and could potentially influence a more equitable distribution of societal benefits [7].

Another significant form of social capital for non-tourism actors within the Pujon Kidul Tourism Village is networking. It has been proposed by study [38] that village communities with intra-group networks are well-positioned to cultivate positive relationships and coordination. A robust network within community relations is postulated to create opportunities for information exchange relating to activities, social funding assistance, and job opportunities. The existence of such a network fosters a sense of shared destiny and responsibilities among individuals, thereby inculcating a culture of mutual assistance and protection.

Currently, community networks among non-tourism actors in Pujon Kidul Tourism Village manifest as a collective willingness to collaborate and participate in the attainment of shared success. Participation in group activities is associated with high trust levels, thereby stimulating cooperative work and involvement in group activities. This trait, prevalent among non-tourism actors in Pujon Kidul Tourism Village, facilitates the effective direction or setting of policies for non-tourism actors through the groups they associate with. This aligns with the proposition by study [39] that networks enable information exchange between interacting individuals, thereby fostering reciprocal relationships. Through robust norms and beliefs as well as extensive networks, a desire to participate in village activities and work together for village development is brought to the fore [40].

While the study provides valuable insights, it is suggested that future research could delve deeper into the nature and dynamics of trust and networking within other community-based tourism villages, and explore the potential influence of these factors on the success of community programs and initiatives.

## 5 Conclusions

This study's conclusions reveal that non-tourism actors within Pujon Kidul Tourism Village possess significant social capital, thereby enhancing community participation for the village's sustainability. It suggests that social capital can serve as a strategy for developing tourism villages by fostering coordinated community participation for shared benefits. A dimension of social capital, namely trust and network, has emerged as a key factor in propelling community involvement in tourism.

Statistical findings imply that trust bolsters the community network within Pujon Kidul Tourism Village by 85.8%, and this network subsequently directly stimulates 30.4% of community participation. These outcomes can be interpreted such that an increase in community trust within the Pujon Kidul Tourism Village directly correlates to an improved relational network. This network augmentation, in turn, boosts community participation in supporting the village's sustainability. The results underscore the community's high trust towards the government and the solid social network within the Pujon Kidul Tourism Village. It is anticipated that maintaining these positive social capital conditions would aid the government in ensuring program effectiveness and building a solid network through community collaboration.

Furthermore, it was observed that the community's willingness to be involved in the tourism village was at an adequate level, considering its purpose and significance. The findings recommend that if the community of Pujon Kidul Tourism Village desires to support the sustainability of the tourism village, involvement in tourism awareness group activities could be beneficial. Engaging in these group activities signifies group membership, which potentially expands opportunities to appreciate the benefits of a tourism village through information exchange and greater understanding of the value of having such a village by capitalizing on opportunities like working in tourism.

Considering these findings, it is recommended for future researchers to conduct a comparative analysis involving tourist villages possessing similar characteristics to Pujon Kidul Tourism Village, where the majority of the population are not tourism actors and local community members do not manage tourism. Such a comparison could determine whether, despite having similar characteristics, communities support or do not support the sustainability of the tourism village based on their social capital and participation levels. If subsequent studies show that those not involved in tourism activities are unwilling to support tourism village sustainability, this might pose a challenge in developing the tourist village, as these villages fundamentally rely on community-based tourism with a regional impact.

Finally, given this study's objective to ascertain the relationship between social capital and community participation, future researchers are advised to further explore other types of social capital variables such as bonding, linking, bridging, and utilize alternative methods of analysis such as Social Network Analysis (SNA). This might yield differing results, focusing more on existing ties within networks within a community group or institution.

## Funding

This paper was funded by Penelitian Dasar Unggulan Perguruan Tinggi (PDUPT) DRTPM DIKTI with LPPM Universitas Brawijaya (Grant No.: 1071.64//UN10.C10/TU/2022).

## Informed Consent Statement

Informed consent was obtained from all subjects involved in the study.

## Data Availability

The data used to support the findings of this study are available from the corresponding author upon request.

## Conflicts of Interest

The authors declare that they have no conflicts of interest.

## References

- [1] J. Yang, R. Yang, M. Chen, C. J. Su, Y. Zhi, and J. Xi, "Effects of rural revitalization on rural tourism," *J. Hosp. Tour. Manag.*, vol. 47, pp. 35–45, 2021. <https://doi.org/10.1016/j.jhtm.2021.02.008>
- [2] K. Ryu, P. A. Roy, H. Kim, and H. B. Ryu, "The resident participation in endogenous rural tourism projects: A case study of kumbalangi in kerala, India," *J. Travel Tour. Mark.*, vol. 37, no. 1, pp. 1–14, 2020. <https://doi.org/10.1080/10548408.2019.1687389>
- [3] B. K. Mak, L. T. Cheung, and D. L. Hui, "Community participation in the decision-making process for sustainable tourism development in rural areas of Hong Kong, China," *Sustainability*, vol. 9, no. 10, p. 1695, 2017. <https://doi.org/10.3390/su9101695>
- [4] Y. Zhang, Y. Xiong, T. J. Lee, M. Ye, and R. Nunkoo, "Sociocultural sustainability and the formation of social capital from community-based tourism," *J. Travel Res.*, vol. 60, no. 3, pp. 656–669, 2021. <https://doi.org/10.1177/0047287520933673>
- [5] T. Ha and P. Nguyen, "Social capital, knowledge sharing and firm performance," *Manag. Sci. Lett.*, vol. 10, no. 12, pp. 2923–2930, 2020. <https://doi.org/10.5267/j.msl.2020.4.014>
- [6] D. Hwang and W. P. Stewart, "Social capital and collective action in rural tourism," *J. Travel Res.*, vol. 56, no. 1, pp. 81–93, 2017. <https://doi.org/10.1177/0047287515625128>
- [7] P. Claiborne, "Community participation in tourism development and the value of social capital-the case of bastimentos, bocas del toro, panamá," 2010. [https://gupea.ub.gu.se/bitstream/handle/2077/22603/gupea\\_2077\\_22603\\_1.pdf;jsessionid=A973BA87119A68999E4D88012546CB8B?sequence=1](https://gupea.ub.gu.se/bitstream/handle/2077/22603/gupea_2077_22603_1.pdf;jsessionid=A973BA87119A68999E4D88012546CB8B?sequence=1)
- [8] W. Shui, Y. Zhang, X. Wang, Y. Liu, Q. Wang, F. Duan, C. Wu, and W. Shui, "Does Tibetan household livelihood capital enhance tourism participation sustainability? evidence from China's Jiaju Tibetan village," *Int. J. Environ. Res. Public Health*, vol. 19, no. 15, p. 9183, 2022. <https://doi.org/10.3390/ijerph19159183>
- [9] W. W. Zhou, L. Y. Chen, and R. J. Chou, "Important factors affecting rural tourists' aesthetic experience: A case study of Zoumatang village in Ningbo," *Sustainability*, vol. 13, no. 14, p. 7594, 2021. <https://doi.org/10.3390/su13147594>
- [10] R. Imansyah, "Impact of internet penetration for the economic growth of Indonesia," *Evergreen*, vol. 5, no. 2, pp. 36–43, 2018. <https://doi.org/10.5109/1936215>
- [11] S. Li and C. Li, "What makes customer participation a double-edged sword: The impact and factors of self-serving bias in agritourism," *J. Destin. Mark. Manag.*, vol. 21, p. 100571, 2021. <https://doi.org/10.1016/j.jdmm.2021.100571>
- [12] X. Ma, R. Wang, M. Dai, and Y. Ou, "The influence of culture on the sustainable livelihoods of households in rural tourism destinations," *J. Sustain. Tour.*, vol. 29, no. 8, pp. 1235–1252, 2021. <https://doi.org/10.1080/09669582.2020.1826497>
- [13] P. Chen and X. Kong, "Tourism-led commodification of place and rural transformation development: A case study of Xixinan village, Huangshan, China," *Land*, vol. 10, no. 7, p. 694, 2021. <https://doi.org/10.3390/land10070694>
- [14] G. Prayitno, D. Dinanti, A. Efendi, A. Hayat, and P. P. Dewi, "Social capital of Pujon Kidul communities in supporting the development of the COVID-19 resilience village," *Int. J. Sustain. Dev. Plan.*, vol. 17, no. 1, pp. 251–257, 2022. <https://doi.org/10.18280/ijdsdp.170125>
- [15] Y. Fitriani and S. Ma'rif, "Manfaat pengembangan desa wisata wonolopo terhadap kondisi sosial, ekonomi dan lingkungan masyarakat lokal (the benefits of developing wonolopo tourism village on the social, economic and environmental conditions of local communities)," *J. Wil. dan Lingkung.*, vol. 5, no. 1, 2017. <https://doi.org/10.14710/jwl.5.1.29-44>

- [16] W. S. Ira and M. Muhamad, "Partisipasi masyarakat pada penerapan pembangunan pariwisata berkelanjutan (studi kasus desa wisata pujon kidul, kabupaten malang)," *J. Par. Terap.*, vol. 3, no. 2, pp. 124–135, 2020. <https://doi.org/10.22146/jpt.43802>
- [17] L. Huang, L. Yang, N. T. Tuyen, N. Colmekcioglu, and J. Liu, "Factors influencing the livelihood strategy choices of rural households in tourist destinations," *J. Sustain. Tour.*, vol. 30, no. 4, pp. 875–896, 2022. <https://doi.org/10.1080/09669582.2021.1903015>
- [18] W. Knollenberg, C. G. Arroyo, C. Barbieri, and K. Boys, "Craft beverage tourism development: The contributions of social capital," *J. Destin. Mark. Manag.*, vol. 20, p. 100599, 2021. <https://doi.org/10.1016/j.jdmm.2021.100599>
- [19] D. Rahayu, I. Chandriyanti, and N. Rahmini, "The tourism economic impact from applied of community based tourism concept (study in kuin tourism village banjarmasin, south kalimantan)," *UNEJ e-Proceeding*, pp. 144–149, 2018. <https://jurnal.unej.ac.id/index.php/prosiding/article/view/6580>
- [20] Y. Narazaki and T. Watanabe, "Social factors affecting innovation cycle of liquid crystal technologies: A Japanese case study," *Evergreen*, vol. 4, no. 4, pp. 8–15, 2017. <https://doi.org/10.5109/1929676>
- [21] R. D. Putnam, *The Prosperous Community*. [https://books.google.co.id/books/about/Prosperous\\_Community\\_Social\\_Capital\\_and.html?id=6pB2nQAACAAJ&redir\\_esc=y](https://books.google.co.id/books/about/Prosperous_Community_Social_Capital_and.html?id=6pB2nQAACAAJ&redir_esc=y)
- [22] J. M. Cohen and N. T. Uphoff, "Participation's place in rural development: Seeking clarity through specificity," *World Dev.*, vol. 8, no. 3, pp. 213–235, 1980. [https://doi.org/10.1016/0305-750X\(80\)90011-X](https://doi.org/10.1016/0305-750X(80)90011-X)
- [23] S. Kitjanukit, "Attitude toward bioremediation-related technology and relation with company social responsibility," *Evergreen*, vol. 6, no. 3, pp. 240–245, 2019. <https://doi.org/10.5109/2349300>
- [24] D. Wahyuni, "Pengembangan desa wisata pentingsari, kabupaten sleman dalam perspektif partisipasi masyarakat," *J. Masalah-Masalah Sosial*, vol. 10, no. 2, pp. 91–106, 2019. <https://doi.org/10.46807/aspirasi.v10i2.1386>
- [25] N. U. Vipriyanti, *Modal Sosial dan Pembangunan Wilayah (Social Capital and Regional Development)*. Malang: UB Press, 2011. [https://books.google.co.id/books/about/Modal\\_sosial\\_dan\\_pembangunan\\_wilayah.html?id=ITyKMAEACAAJ&redir\\_esc=y](https://books.google.co.id/books/about/Modal_sosial_dan_pembangunan_wilayah.html?id=ITyKMAEACAAJ&redir_esc=y)
- [26] E. Okazaki, "A community-based tourism model: Its conception and use," *J. Sustain. Tour.*, vol. 16, no. 5, pp. 511–529, 2008. <https://doi.org/10.1080/09669580802159594>
- [27] S. Haryono, "Metode SEM untuk penelitian manajemen dengan AMOS LISREL PLS," *Luxima Metro Media*, vol. 450, 2017.
- [28] A. T. Nugraha, G. Prayitno, A. W. Hasyim, and F. Roziqin, "Social capital, collective action, and the development of agritourism for sustainable agriculture in rural Indonesia," *Evergreen*, vol. 8, no. 1, pp. 1–12, 2021. <https://doi.org/10.5109/4372255>
- [29] N. Noorashid and W. L. Chin, "Coping with COVID-19: The resilience and transformation of community-based tourism in brunei darussalam," *Sustainability*, vol. 13, no. 15, p. 8618, 2021. <https://doi.org/10.3390/su13158618>
- [30] R. Musavengane and R. Kloppers, "Social capital: An investment towards community resilience in the collaborative natural resources management of community-based tourism schemes," *Tour. Manag. Perspect.*, vol. 34, p. 100654, 2020. <https://doi.org/10.1016/j.tmp.2020.100654>
- [31] X. Font and S. McCabe, "Sustainability and marketing in tourism: Its contexts, paradoxes, approaches, challenges and potential," *J. Sustain. Tour.*, vol. 25, no. 7, pp. 869–883, 2017. <https://doi.org/10.1080/09669582.2017.1301721>
- [32] J. Phillipson, M. Gorton, R. Turner, *et al.*, "The COVID-19 pandemic and its implications for rural economies," *Sustainability*, vol. 12, no. 10, p. 3973, 2020. <https://doi.org/10.3390/SU12103973>
- [33] S. B. Dash and P. Sharma, "Reviving indian tourism amid the COVID-19 pandemic: Challenges and workable solutions," *J. Destin. Mark. Manag.*, vol. 22, p. 100648, 2021. <https://doi.org/10.1016/j.jdmm.2021.100648>
- [34] N. Ćurčić, A. Mirković Svitlica, J. Brankov, Ž. Bjeljic, S. Pavlović, and B. Jandžiković, "The role of rural tourism in strengthening the sustainability of rural areas: The case of Zlakusa village," *Sustainability*, vol. 13, no. 12, p. 6747, 2021. <https://doi.org/10.3390/su13126747>
- [35] N. T. Kuo, Y. S. Cheng, K. C. Chang, and S. M. Hu, "How social capital affects support intention: The mediating role of place identity," *J. Hosp. Tour. Manag.*, vol. 46, pp. 40–49, 2021. <https://doi.org/10.1016/j.jhtm.2020.11.005>
- [36] O. Soliku, B. Kyiire, A. Mahama, and C. Kubio, "Tourism amid COVID-19 pandemic: Impacts and implications for building resilience in the eco-tourism sector in Ghana's Savannah region," *Heliyon*, vol. 7, no. 9, p. e07892, 2021. <https://doi.org/10.1016/j.heliyon.2021.e07892>
- [37] B. Lopaciuk-Goncaryk, "Does participation in social networks foster trust and respect for other peo-

- ple—Evidence from Poland,” *Sustainability*, vol. 11, no. 6, p. 1733, 2019. <https://doi.org/10.3390/su11061733>
- [38] A. T. Nugraha, R. Rahmawati, A. Auliah, and G. Prayitno, “Farmers’ social capital in supporting sustainable agriculture: The case of Pujon Kidul tourism village, Indonesia,” *CIVENSE*, vol. 5, no. 2, pp. 235–249, 2022. <https://doi.org/10.21776/ub.civense.2022.00502.12>
- [39] B. M. R. Farisa, G. Prayitno, and D. Dinanti, “Social capital and community participation on infrastructure development in pajaran village, malang regency Indonesia,” *IOP Conf. Ser.: Earth Environ. Sci.*, vol. 239, no. 1, p. 012046, 2019. <https://doi.org/10.1088/1755-1315/239/1/012046>
- [40] G. Prayitno and M. Syaifurridzal, “Social capital and public participation on planning in coastal area development,” *IOP Conf. Ser.: Earth Environ. Sci.*, vol. 79, no. 1, p. 012019, 2017. <https://doi.org/10.1088/1755-1315/79/1/012019>